

## Modelling Viscous Behaviour of Clayey Geomaterials using Single Mechanical-Analogue Model

(Pemodelan Sifat Kelikatan Bahan Geologi Berlumpur menggunakan Model Analog Mekanik Tunggal)

NOR SHAHIDAH MOHD NAZER\*

### ABSTRACT

*The design of sustainable early warning systems for landslide prone areas requires deep understanding of the kinematic of landslides with emphasis on the evolution of its movement. This is controlled by many factors, and creep is a major one. Creep is perceptively slow land sliding process where the movement is nearly imperceptible and occurring at a rate of millimetres (mm) per year. This article reports the results of investigations of the viscous shear behaviour of clayey geo-materials, in particular creep and relaxation, which were carried out using a direct shear box. The viscous behaviour was investigated by either measuring the decay in shear stress at constant relative horizontal displacement (stress relaxation test) or by measuring the evolution of relative horizontal displacements at constant shear stress (creep test). Initially, 3 elements model of spring and dashpots combination was proposed to simulate the viscous behaviour of clayey geo-materials. However, because the loading system of direct shear box is not stiff and is showing some creep/relaxation interplay during viscous test, effect from the compliance system of the shear box must be carefully considered when formulating mechanical models for saturated and unsaturated slope kinematics. Another elastic element was added to the 3 elements model to address the issue of deforming loading system. The proposed modified model capable of simulating creep and stress relaxation response using a single set of parameters and thus, allowing creep response to be inferred from stress relaxation response by means of direct shear test in lab.*

*Keywords: Clayey geomaterials; mechanical-analogue model; modelling; viscous*

### ABSTRAK

*Penciptaan Sistem Amaran Awal untuk kawasan dedahan tanah runtuh memerlukan pemahaman mendalam terhadap kinematik tanah runtuh dengan penekanan terhadap evolusi pergerakannya. Ianya dikawal oleh banyak faktor, dan rayapan adalah yang paling utama. Rayapan adalah proses pergerakan tanah secara perlahan kerana pergerakan adalah hampir tidak dapat dikesan dan berlaku pada kadar milimeter (mm) setiap tahun. Kertas ini melaporkan hasil kajian sifat kelikatan ricihan bahan geo-lempung, khususnya rayapan dan santaian, dilakukan menggunakan kotak ricih terus. Sifat kelikatan dikaji melalui pengukuran pereputan tekanan ricih pada anjakan mendatar seragam relatif (ujian santaian tekanan) atau melalui pengukuran evolusi anjakan mendatar relatif pada tekanan ricihan seragam (ujian rayapan). Asalnya, model 3 unsur yang terdiri daripada gabungan spring dan peredam telah dicadangkan untuk mensimulasi sifat kelikatan bahan geo-lempung. Walau bagaimanapun, memandangkan sistem bebanan kotak ricih terus tidak pegun dan menunjukkan sedikit saling rayapan/santaiian semasa ujian kelikatan, kesan daripada sistem pematuhan kotak ricih terus mestilah diambil kira dengan waspada sewaktu merumuskan model mekanik bagi kinematik cerun tepu dan tidak tepu. Unsur elastik tambahan telah ditambah kepada model 3 unsur untuk mengatasi masalah kebolehubahan bentuk sistem bebanan. Model berubah suai yang dicadangkan berkebolehan mensimulasi tindak balas rayapan dan tekanan santaian menggunakan set parameter tunggal dan maka dengan itu, membolehkan tindak balas rayapan dijana daripada tekanan santaian melalui ujian kotak ricih terus di makmal.*

*Kata kunci: Bahan geologi berlumpur; kelikatan; model analog mekanikal; pemodelan*

### INTRODUCTION

When evaluating the kinematics of rainfall-triggered landslides, be it a natural or a man-made slope, engineers and researchers tend to look at the empirical correlations between the displacement and rainfall distributions and these are extrapolated to simulate slope displacement associated with future rainfall events. However, a sound Early Warning System (EWS) should be based on a model

of the slope kinematics and historical data should be used to calibrate the model rather than developing an empirical correlation.

Early warning systems (EWS) are generally designed to forecast landslide hazard by detecting hazards and risk zones. Designing simple EWS is important so as to avoid confusion and loss of time during emergencies (Intrieri et al. 2013). Sound EWSs must be underpinned by properly

designed mechanical models, in turn calibrated against field monitoring data, to allow for accurate projection of future movements. A large number of creep models in the literature, associated with early warning system for rainfall-induced landslides, are based on empirical models rather than physically-based models (Furuya et al. 1999; Yang et al. 2017). Empirical models are known to be limited to a specific boundary conditions and do not provide clear conceptual understanding of landslide kinematics. Empirical models therefore offer limited application and also lack theoretical basis (Huang et al. 2014).

Here, we aim to simulate viscous response in shear behaviour of clayey geo-materials using a mechanical analogue model built upon the combinations of spring and dashpots. The model had proven successful in simulating creep response for both saturated and unsaturated conditions as shown previously (Nazer 2017). With that regard, creep and relaxation are now simulated using a single model, i.e. using a single set of parameters, and not treated separately as often happens when empirical models are used. Using a single model to capture both creep and relaxation is important in modelling the kinematics of a landslide since viscous response of clay geo-materials that controls landslide movements is never purely 'creep' mode because effective stress varies due to rainwater infiltration and/or groundwater fluctuation (Lai et al. 2014).

Existing viscous models typically address either strain/displacement creep or stress relaxation which is not ideal when dealing with landslide case study where in reality the landslide is never subjected to 'pure' creep because effective stress changes as a result of rainwater infiltration and/or groundwater pressure fluctuation. Although the idea of modelling time-dependent (viscous) behaviour of landslides is not new, adopting a single model that works simultaneously for creep and stress relaxation appears to be original and significant for the implementation in an Early Warning System for rainfall-induced landslides.

The direct shear box is a commercially available apparatus that can be conveniently used to investigate creep response. Conventional direct shear box operates in displacement-control and can only be used to conduct stress relaxation tests. If a unified creep/relaxation model is used to interpret the relaxation tests, relaxation data can then be used to simulate creep response. However, the system compliance from direct shear box was not stiff and causes some inconsistency to the creep and relaxation response recorded from the laboratory tests. These can be seen from the 3 elements model developed earlier which fails to simulate creep and relaxation response simultaneously using a single set of parameters. Another elastic element was then added to the model where it seems to satisfactorily capture the viscous response with single set of parameters (Nazer 2017).

In this paper, we proposed the use of direct shear box for viscous test of clayey geo-materials and we developed a mechanical analogue model with additional elastic elements to account for system compliance that works simultaneously for creep and relaxation.

## MATERIALS AND METHODS

### CONVENTIONAL DIRECT SHEAR BOX

Figure 1 shows the conventional direct shear box used in this research. A conventional direct shear box measures shear strength of soils. Even though the stress pattern is complex where the stress conditions in the specimen during the test are not known and the directions of the planes of principal stress rotate as the test proceeds and the distribution of stresses along the plane of shear is non-uniform, however, test duration is relatively short, making it very suitable for practical applications.

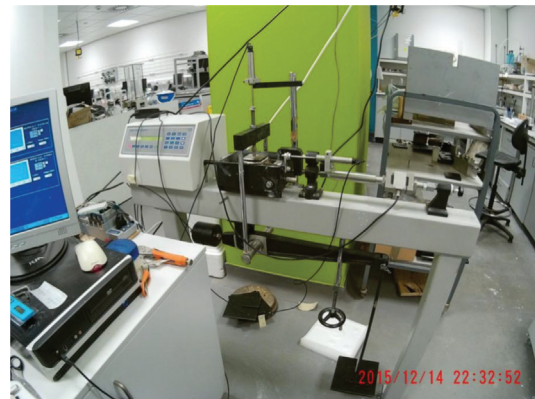

FIGURE 1. Conventional direct shear box for stress relaxation test

This direct shear box consists of a shear box body for testing specimens 60 mm square or 100 mm square section, a shear box carriage running on roller bearings, and a step motor drive unit to apply horizontal displacements at constant rate. The apparatus was equipped with a S-load cell for measuring the horizontal shear force (5000 N capacity with a measured standard deviation of accuracy of N) and two potentiometer displacement transducers for measuring the horizontal and vertical displacements (15 mm travel with measured standard deviation of accuracy of  $\pm 3$   $\mu$ m). Vertical load was applied with a lever-arm loading system with 10: 1 beam ratio.

Material used in this research was a reconstituted Ball Clay. The specimen was labelled Sat-PRP-MS-100-50 which simply means; it was tested under saturated condition, it was then sheared below peak shear strength, the test was a multistage test where several 'pit-stops' were chosen (at selected shear stress level) to allow the specimen to creep/relax, specimen was applied with 100kPa normal stress and the tangential stress at which the specimen was sheared to and stopped at was equivalent to 50 % of peak shear strength.

### MODIFIED DIRECT SHEAR BOX (FORCE-CONTROLLED)

The conventional direct shear box was modified to study creep behavior. The modification involves an additional

pulley system, which was connected to the external container and, hence, to the lower frame. The pulley was a non-friction pulley with string made of steel. During loading, tension force was applied by the pulley system to the lower frame and converted into shear force applied to the specimen by load cell, causing this latter to be sheared at constant shear force (Figure 2).

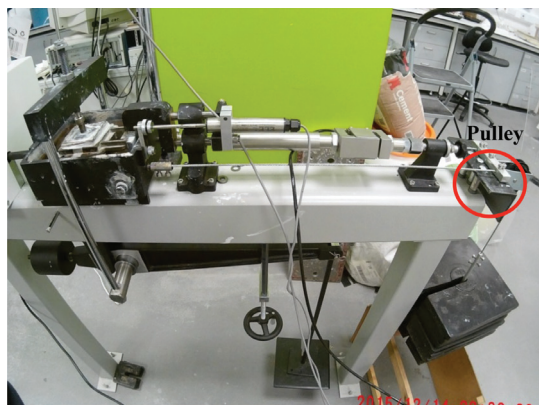

FIGURE 2. Modified direct shear box with addition of pulley system for creep test

#### CALIBRATION OF THE COMPLIANCE SYSTEM

The loading system was calibrated by assessing its elastic and/or viscous response, which should be discounted in the creep and relaxation tests carried out on the soil specimens. A rigid dummy sample made of steel was used to ensure that any displacement recorded during the calibration tests was generated by the elastic and/or viscous response of the loading system only. Assumption was made that the steel dummy sample did not exhibit any creep.

It was desirable that the loading system exhibited negligible viscous response to minimise errors in the measurement of the viscous response of the clay. On the other hand, it was expected that the loading system exhibited some deformability, which needed to be assessed due to its effects on the measured stress decay in relaxation

tests. During the calibration tests, the displacements experienced by the upper and lower frames were recorded with displacement transducers (Figure 3).

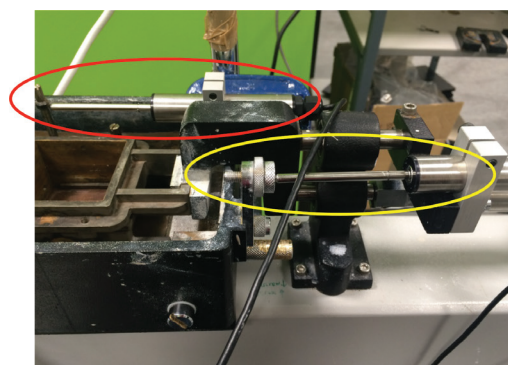

FIGURE 3. Calibration of the loading system; two horizontal transducers to measure relative displacements of bottom half (yellow) and top half (red)

#### CALIBRATION IN 'CREEP' MODE: STIFFNESS OF THE HOLDING ARM

Figure 4 shows the schematic layout of the calibration test in 'creep' mode. The horizontal load was applied to the bottom frame via the external container while the upper frame was maintained in place by the horizontal holding arm connected in series with the load cell. In principle, when the specimen is tested in creep mode, the bottom frame is the one moving in the direction of shear whereas the upper frame should remain locked in place by the horizontal holding arm. However, calibration test using dummy sample has showed that the horizontal holding arm deforms when compressed axially as a consequence of the shear force applied to the bottom frame via the external container.

Figure 5 shows the relationship between the deformation of the horizontal holding arm (measured by the displacement transducer circled in red in Figure 3) and the horizontal arm axial force expressed in equivalent shear

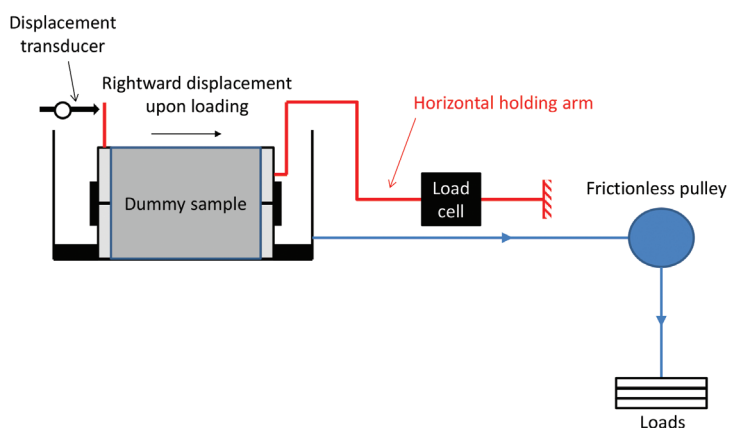

FIGURE 4. Schematic layout of calibration test in 'creep' mode

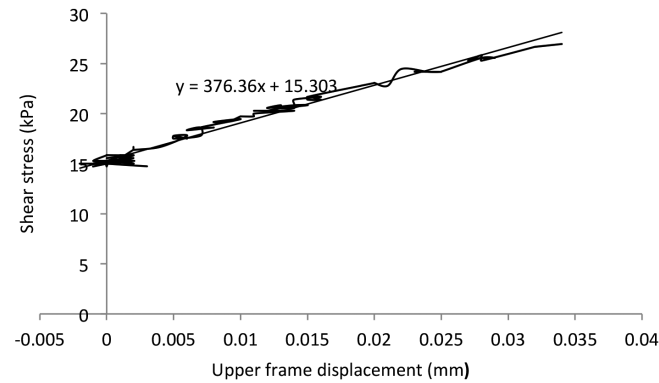

FIGURE 5. Stiffness of horizontal holding arm

stress for a 60 mm side specimen. The slope of the shear stress versus the upper-frame displacement plot represents the stiffness of the horizontal holding arm.

#### CALIBRATION IN 'RELAXATION' MODE: STIFFNESS OF THE LOADING ARM

Figure 6 shows the schematic layout of the calibration test in 'relaxation' mode. In the stress relaxation test, the shear stress 'relaxes' at constant horizontal displacement. Therefore, a condition where no displacement is generated to allow for pure stress relaxation will only be achieved if the lower frame remains locked in place, i.e. the horizontal loading arm connected to the external container does not deform, and also the upper frame remains locked in place, i.e. the horizontal holding arm does not deform.

Initially, the calibration of the system was performed using a dummy sample made of steel. However, the deformations of the horizontal loading arm and the horizontal holding arm recorded once the step motor was stopped were very small (same order of magnitude as the accuracy of the displacement transducer). As a result, the stiffness of the loading system could not be calculated and another approach had to be pursued.

It was then noted that, during the relaxation test performed on the soil specimen, the displacement of the external container and, hence, of the lower frame was not constant once the step motor was stopped. The decay in shear stress caused the horizontal loading arm to decompress generating a further right-ward movement of the external container.

This is clearly illustrated in Figure 7(a). When the horizontal displacement was imposed at constant rate, the shear stress increased as expected. At the horizontal displacement of around 0.20 mm, the step-motor was stopped to virtually impose a no further displacement between the two shear box frames. However, it can be seen that the lower frame keeps moving forward due to the decompression of the horizontal loading arm as the shear stress decays.

The slope of the shear stress versus the lower-frame displacement in the 'relaxation stage' as shown in Figure 7(b) could therefore be taken as the stiffness of the horizontal loading arm.

#### VISCOUS RESPONSE OF THE LOADING SYSTEM

In the calibration tests in 'creep' mode, the displacement was recorded versus time to detect possible viscous behaviour of the loading system. No displacements were recorded versus time: Once the load was applied in creep mode as shown in Figure 8; and once the step-motor was stopped in relaxation mode using the dummy sample as shown in Figure 9.

## RESULTS AND DISCUSSION

### MODELLING SIMULATION

To understand viscous response of the clay geo-materials, analogue mechanical models were built using combinations

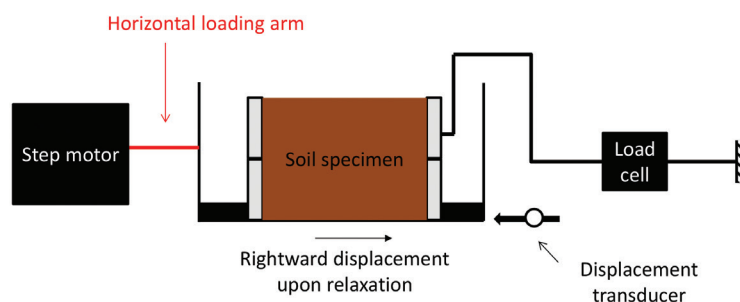

FIGURE 6. Schematic layout of calibration test in 'relaxation' mode

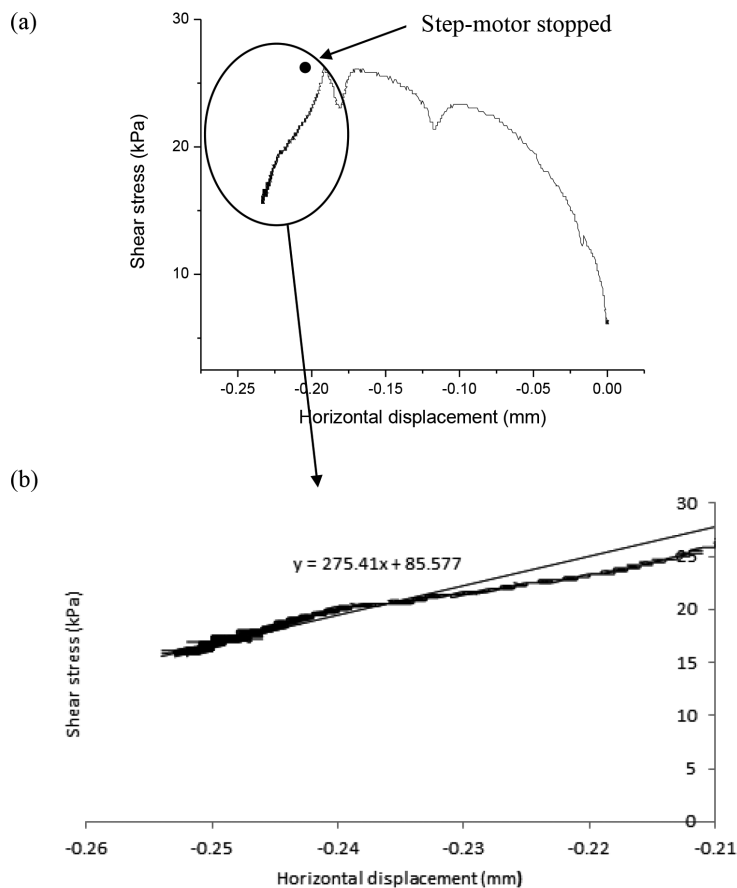

FIGURE 7. Stiffness of horizontal loading arm, (a) Shear stress versus horizontal displacement in a displacement-controlled direct shear test, and (b) Horizontal displacement accumulated once the step-motor was stopped

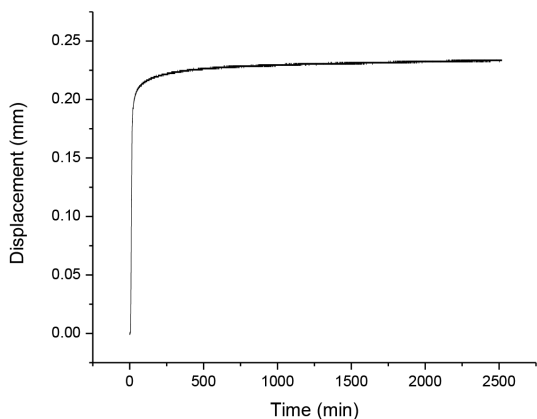

FIGURE 8. Time response in creep mode once the load was applied to the system

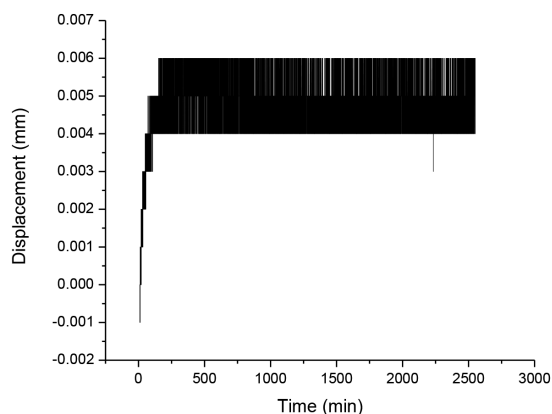

FIGURE 9. Time response in relaxation mode using a dummy sample once the step-motor was stopped

of springs and dashpot, i.e. generalized Kelvin and Maxwell models, were considered. These models allow capturing creep and relaxation response using a single set of parameters. The models were developed analytically and constitutive equations derived from the models were used to simulate experimental results. Three element models were initially selected (Figure 10).

Figure 11 shows the performance of the 3-element models M3a and M3b for Sat-PRP-MS-100-50 (Saturated-Pre-Peak-Multistage test-100kPa normal stress-tangential stress at 50% of peak shear strength). These models strictly predict an asymptotic behaviour that is stabilization of displacement in creep mode and of stress in relaxation mode. It can be seen that the same model based on a

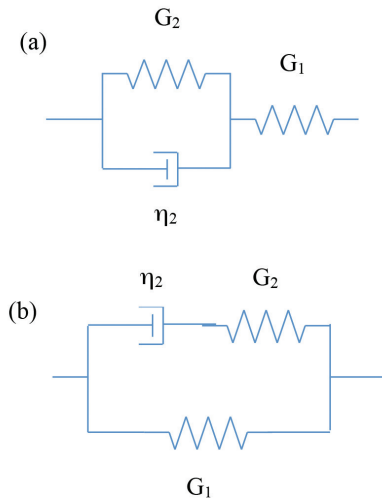

FIGURE 10. 3-element mechanical models, (a) Kelvin model in parallel with a spring and (b) Maxwell model in series with a spring

single set of parameters fails to capture both creep and relaxation response. The model parameters were fitted onto the creep response. However, it appears that the same set of parameters is not capable of capturing the relaxation response. If the parameters were adjusted to fit the stress relaxation response, the creep on the other hand would have been poorly captured.

However, because the loading system of direct shear box is not stiff and is showing some creep/relaxation

interplay during viscous test, another elastic element was added to the model to address the issue of the deforming loading system. The 3-element model works well in capturing the final value of creep displacement and relaxation stress (end here refers to end of viscous test, not the viscous process as a whole) using a single set of parameters. The reason why a single set of parameters fails in capturing simultaneously creep and relaxation response is not surprising if the relaxation and creep equations are inspected in model detail. If  $\gamma_0$  and  $\gamma_\infty$  are the initial and final (creep) displacement and  $\sigma_0$  and  $\sigma_\infty$  are the initial and final (relaxation) stress, respectively, it can be easily shown that the models return the same ratios for  $\gamma_\infty/\gamma_0$  and  $\sigma_0/\sigma_\infty$ ,

$$\frac{\gamma_\infty}{\gamma_0} = \frac{\sigma_0}{\sigma_\infty} = \frac{G_1}{G_2} + 1 \tag{1}$$

$$\frac{\gamma_\infty}{\gamma_0} = \frac{\sigma_0}{\sigma_\infty} = 1 + \frac{G_2}{G_1} \tag{2}$$

It clearly shows that the ratios  $\gamma_\infty/\gamma_0$  and  $\sigma_0/\sigma_\infty$  are not equal experimentally as shown in Figure 11. As a result, the same model cannot simulate creep and relaxation with a single set of parameters.

It was therefore suspected that this inconsistency was associated with the compliance of the system, i.e. the initial displacement  $\gamma_0$  is affected by the deformation of the loading system and the relaxation stress  $\sigma_\infty$  is also controlled by the stiffness of the loading system. If this was true, creep and relaxation should be captured by a single set of parameters if the compliance of the system is properly accounted for.

(3+1)-ELEMENT VISCO-ELASTIC MODELS (ADDITIONAL SPRING TO ACCOUNT FOR LOADING SYSTEM COMPLIANCE)

Figure 12 shows the 3 elements mechanical models with additional spring to account for loading system deformation ( $G_3$ ). Figure 13 shows a modelling simulation example with (3+1)-element model, M(3+1)a and M(3+1)b, for the case of saturated pre-peak at 100kPa vertical stress, with shear stress level of 50% of peak shear strength. These 2 models were originated from the 3-element models mentioned above but with an additional elastic element to account for the compliance of the loading system.

The stiffness of the additional spring  $G_3$  was derived from the calibration illustrated in Figure 5. For the simulation of creep, only the stiffness of the holding arm was considered and derived from the calibration shown in Figure 4. For the simulation of relaxation, both the loading arm and the holding arm were considered. The stiffness of the holding arm was again derived from the calibration shown in Figure 4. The stiffness of the loading arm was derived by test according to the procedure illustrated in Figure 6.

A single set of parameters seems to capture fairly well the final creep displacement and relaxation stress,

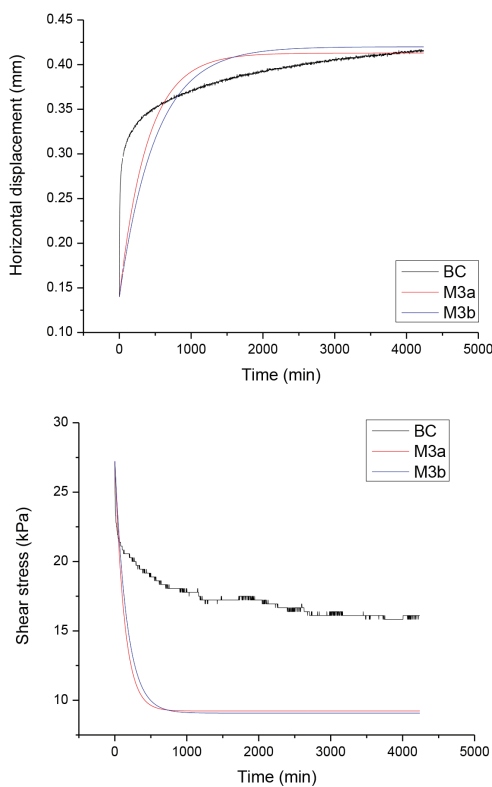

FIGURE 11. Simulation of creep and relaxation response with 3-elements models, M3a and M3b

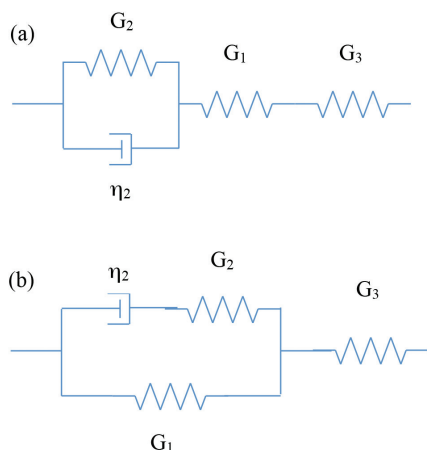

FIGURE 12. (3+1)-element mechanical model with additional spring to account for compliance of the loading system

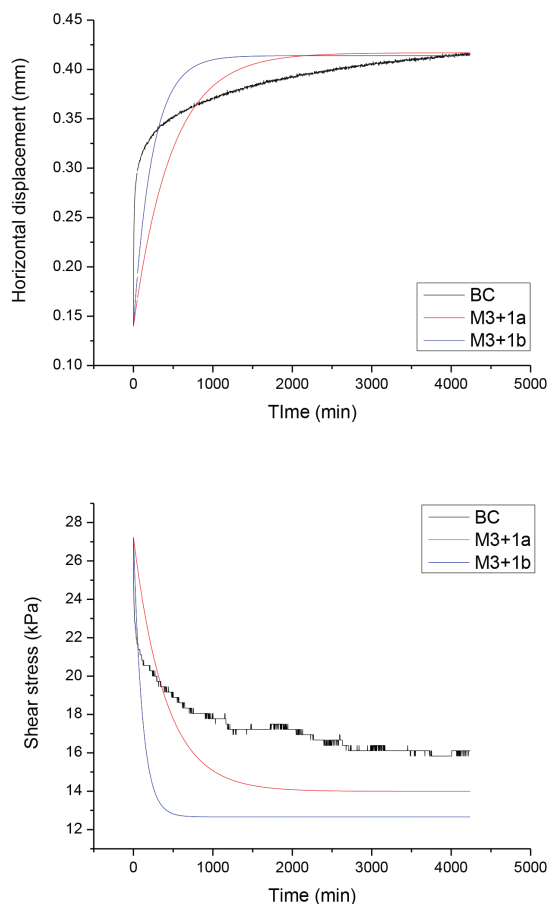

FIGURE 13. Simulations of creep and relaxation with (3+1)-element models, M(3+1)a and M(3+1)b

especially by the Model 3+1a as shown in Figure 13. Model 3+1a captured the response in creep well but underestimate the stress relaxation response. By comparison with the Model M3a performances, the simulations by the Model 3+1a were considered satisfactory. Model 3+1b, despite having captured the response in creep well, is less satisfactory in simulating the stress relaxation response.

This shows that relaxation and creep responses are associated with the same viscous response. This conclusion is less trivial than it seems at first glance. In the literature, creep and relaxation are very often treated separately and empirical models are generally used to fit experimental data. The simulation shows that viscous behaviour can be tested and calibrated in ‘relaxation’ mode and then extrapolated to the creep mode.

The importance of including the compliance of the system in the modelling of the viscous response is shown in Figure 14 where the performance of the models M3a and M(3+1)a, without and with the additional spring to account for the system compliance, respectively, are compared. In both cases, model parameters were derived to match the creep simulation. It can be observed that the additional spring to account for the system compliance significantly improves the simulation.

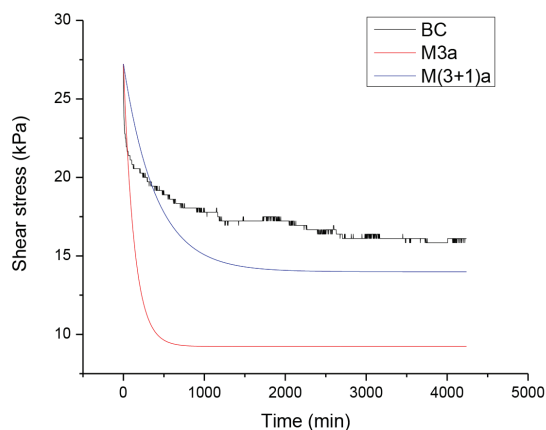

FIGURE 14. Comparison between simulation in stress relaxation for 3-elements model, with and without additional spring to account for loading system compliance

## CONCLUSION

Viscous response of Ball Clay in shear has been investigated by means of direct shear box. It was shown that this can be achieved provided the experimental data are corrected to account for the compliance of the loading system. In the relaxation tests, once the step motor connected to the loading arm is stopped, the shear stress decays causing a deformation of the loading and holding arm. In other words, relaxation does not occur under ideal ‘zero’ shear displacement conditions because of the deformation of the loading system. However, if the deformability of the loading system is accounted for in the modelling, this effect can be ‘corrected’. A different procedure was considered to quantify the stiffness of the loading system depending on whether tests were carried out in displacement-control (both loading and holding arm were considered) or stress control (only the holding arm was considered) modes. Using a Kelvin model in series with a spring (plus the additional spring to account for the compliance of the system), it was shown the stress decay ratio and the shear

displacement increase ratio can be reasonably captured by a single set of parameters using this model. This paves the way for an approach to modelling viscous behaviour using conceptual models rather than empirical ones.

#### ACKNOWLEDGEMENTS

The author would like to express sincere gratitude to the most-respect, Prof. Alessandro Tarantino from the University of Strathclyde, Glasgow for his tremendous help and guidance in this research. His help with modelling and data interpretation was indeed the main factor for this research's success.

#### REFERENCES

- Furuya, G., Sassa, K., Hiura, H. & Fukuoka, H. 1999. Mechanism of creep movement caused by landslide activity and underground erosion in crystalline schist, Shikoku Island, Southwestern Japan. *Engineering Geology* 53(3): 311-325.
- Huang, W., Liu, D.Y., Zhao, B.Y., Feng, Y.B. & Xia, Y.C. 2014. Study on the rheological properties and constitutive model of Shenzhen mucky soft soil. *J. Eng. Sci. Technol. Rev* 7(3): 55-61.
- Intrieri, E., Gigli, G., Casagli, N. & Nadim, F. 2013. Brief communication 'Landslide early warning system: Toolbox and general concepts'. *Natural Hazards and Earth System Sciences* 13(1): 85-90.
- Lai, X.L., Wang, S.M., Ye, W.M. & Cui, Y.J. 2014. Experimental investigation on the creep behavior of an unsaturated clay. *Canadian Geotechnical Journal* 51(6): 621- 628.
- Nazer, N.S.M. 2017. Geohazard modelling of creeping landslide by mechanical-analogue model. *Sains Malaysiana* 46(12): 2325-2329.
- Yang, Z.J., Jian, P.Q., Dong, H., Taro, U. & Lin, W. 2017. Experimental identification on thresholds for early warning of rainfall-induced failure on fractured slopes after giant earthquake. *Sains Malaysiana* 46(11): 2029-2034.

Centre for Earth Sciences and Environment  
Faculty of Science and Technology  
Universiti Kebangsaan Malaysia  
43600 UKM Bangi, Selangor Darul Ehsan  
Malaysia

\*Corresponding author; email: shahidahnazer@ukm.edu.my

Received: 4 April 2019

Accepted: 15 August 2019